

Invoq



Invoq Drain Lift System – Optimise your kitchen efficiency

Upgrade your kitchen operations with our advanced Drain Lift System designed specifically for Invoq ovens. Say goodbye to drainage issues and costly external pumps – our all-in-one solution is here to transform your culinary experience.

WHITE PAPER

Easy pumping of wastewater

The drain lift system for Invoq ovens is a ready-to-install, external, automatic drainage system with an integrated pump, intended to lift wastewater out into a wall mounted drain.

Seamless integration

The Invoq Drain Lift System is seamlessly integrated with our ovens, creating a harmonious union with the oven's software. This smart technology ensures a controlled pace of wastewater removal, eliminating the risk of overflow and providing uninterrupted kitchen workflow.

Cost-efficiency

External pumps can be a significant expense. With the Invoq Drain Lift System, you can expect to reduce these costs to approximately 10% of the price. Not only does it save you money, but it also optimises your overall kitchen budget.

Versatile application

This system is perfect for various kitchen setups with Invoq floor models i.e. roll-in ovens or Stackit solution. Frequently seen in basement kitchens and other locations with wall-mounted drains, its adaptability makes it an ideal choice for a wide range of culinary environments.

The tundish allows for a wall installation of a height up to 350 mm.

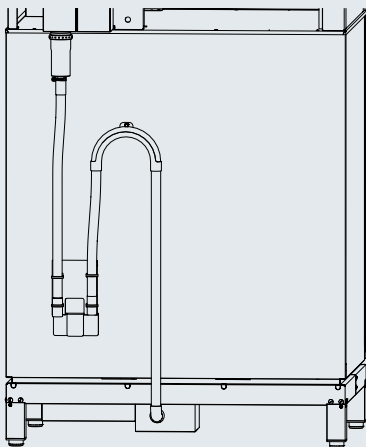

Drain lift system on a Stackit oven

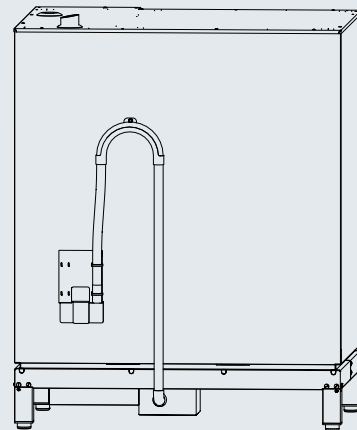

Drain lift system on a standard oven

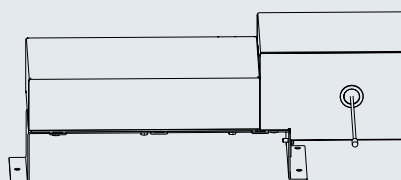

Drain box and pump assembly